

MICRO & MINI MILLER

Cast Iron Pipes

DESCALING

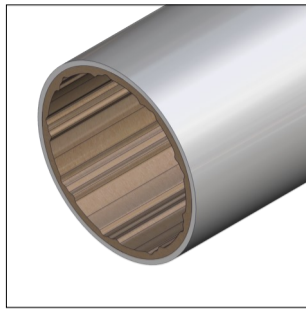

INTACT

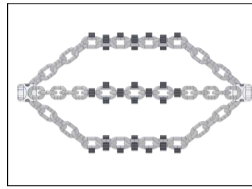

Original Chain

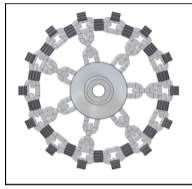

Cyclone Chain



3D Chain (Premium)

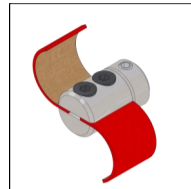

Smart Cutter™

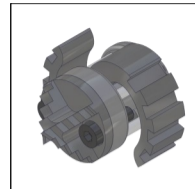

Mini Smart Sweeper

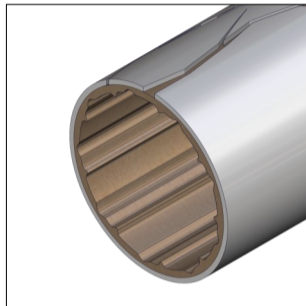

FRAGILE

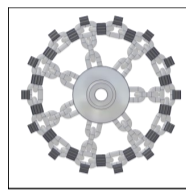

Cyclone Chain

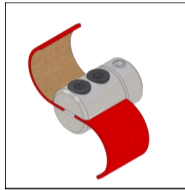

Smart Cutter™

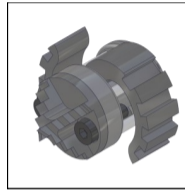

Mini Smart Sweeper

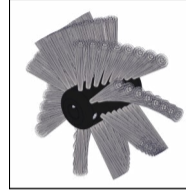

Wire Brush

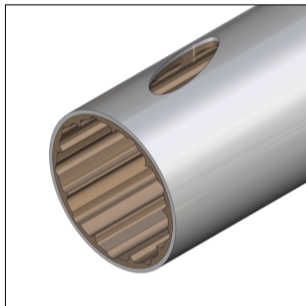

DAMAGED

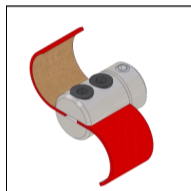

Smart Cutter™

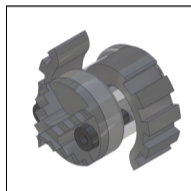

Mini Smart Sweeper

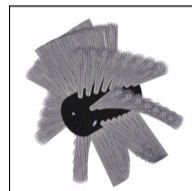

Wire Brush

SPECIAL

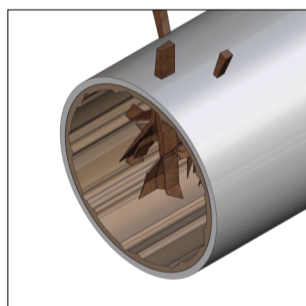

ROOTS

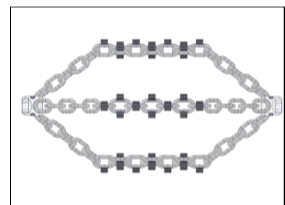

Original Chain

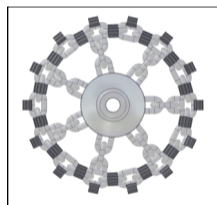

Cyclone Chain



3D Chain (Premium)



Twister Mini Express

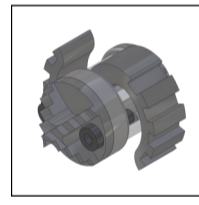

Mini Smart Sweeper

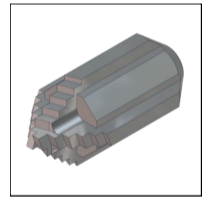

Special Drill Head

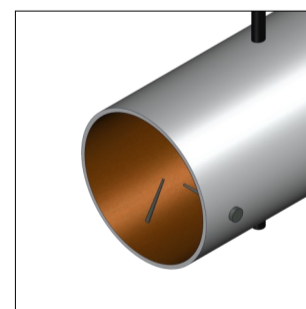

METAL

Refer to the Midi, Super Midi and Maxi Miller Range of Machines

Micro Miller

Shaft Diameter: 8 mm (1/3")

Micro Miller Range: 12 metres (39 ft)

Additional Extension:** 10 metres (32 ft)

Recommended Diameter Range: DN50 (2") to DN100 (4")

Mini Miller

Shaft Diameter: 8 mm (1/3")

Mini Miller Range: 16 metres (50 ft)

Additional Extension:** 10 metres (32 ft)

Recommended Diameter Range: DN50 (2") to DN100 (4")

** Shaft extension sold separately.

Available Tools

Original Chain (Standard)

Original Chain (Premium)

3D Chain (Premium)

Cyclone Chain (Standard)

Cyclone Chain (Premium)

Smart Cutter™

Wire Brush*

Special Drill Head

Twister Mini Express

Mini Smart Sweeper

Size Diameter

DN50 (2") - DN150 (6")

DN50 (2") - DN150 (6")

DN50 (2") - DN100 (4")

DN70 (3") - DN150 (6")

DN70 (3") - DN125 (5")

DN50 (2") - DN100 (4")

DN50 (2") - DN150 (6")

DN50 (2") - DN75 (3")

DN50 (2") - DN75 (3")

DN50 (2") - DN75 (3")

* Wire brushes should only be used for removing fine dust or light mineral deposits.

Clay Pipes

DESCALING

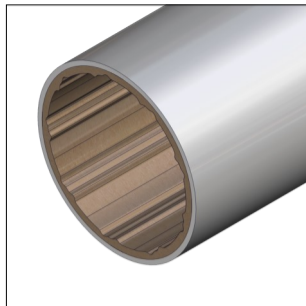

INTACT

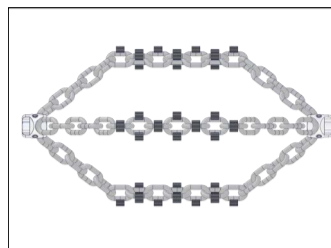

Original Chain

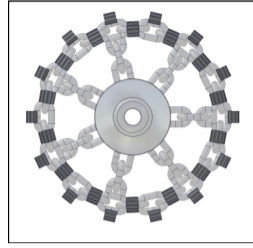

Cyclone Chain



3D Chain (Premium)

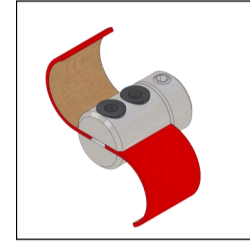

Smart Cutter™

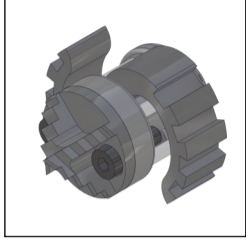

Mini Smart Sweeper

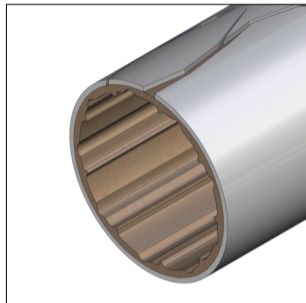

FRAGILE

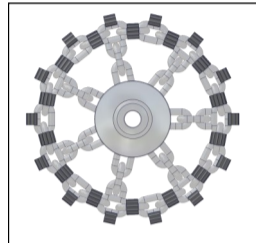

Cyclone Chain



Smart Cutter™

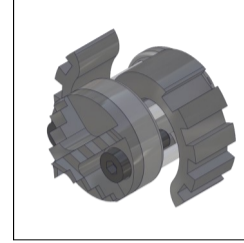

Mini Smart Sweeper

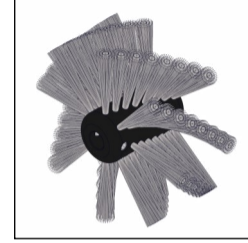

Wire Brush

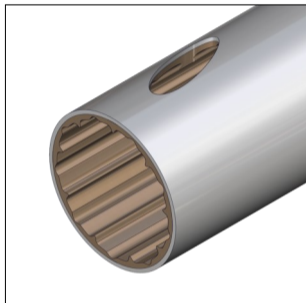

DAMAGED

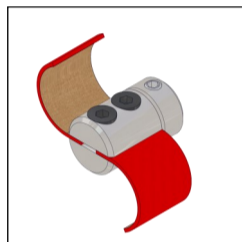

Smart Cutter™

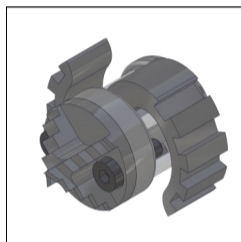

Mini Sweeper

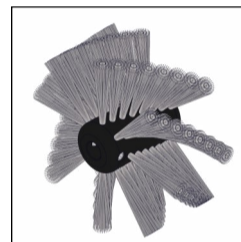

Wire Brush

SPECIAL

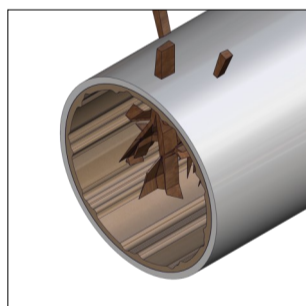

ROOTS

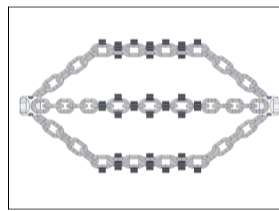

Original Chain

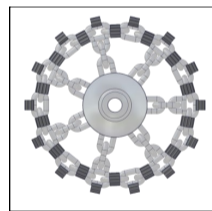

Cyclone Chain



3D Chain (Premium)



Twister Mini Express

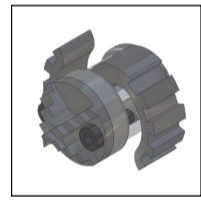

Mini Smart Sweeper

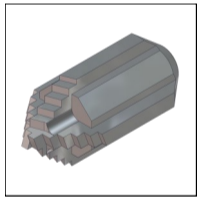

Special Drill Head

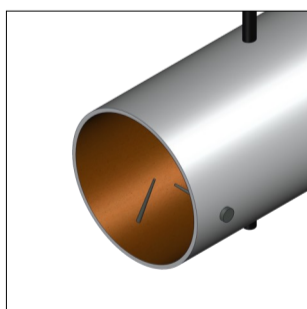

METAL

Refer to the Midi, Super Midi and Maxi Miller Range of Machines

Micro Miller

Shaft Diameter: **8 mm (1/3")**

Micro Miller Range: **12 metres (39 ft)**

Additional Extension:** **10 metres (32 ft)**

Recommended Diameter Range: **DN50 (2") to DN100 (4")**

Mini Miller

Shaft Diameter: **8 mm (1/3")**

Mini Miller Range: **16 metres (50 ft)**

Additional Extension:** **10 metres (32 ft)**

Recommended Diameter Range: **DN50 (2") to DN100 (4")**

Available Tools

Original Chain (Standard)
Original Chain (Premium)
3D Chain (Premium)
Cyclone Chain (Standard)
Cyclone Chain (Premium)
Smart Cutter™
Wire Brush*
Special Drill Head
Twister Mini Express
Mini Smart Sweeper

Size Diameter

DN50 (2") - DN150 (6")
DN50 (2") - DN150 (6")
DN50 (2") - DN100 (4")
DN70 (3") - DN150 (6")
DN70 (3") - DN125 (5")
DN50 (2") - DN100 (4")
DN50 (2") - DN150 (6")
DN50 (2") - DN75 (3")
DN50 (2") - DN75 (3")
DN50 (2") - DN75 (3")

* Wire brushes should only be used for removing fine dust or light mineral deposits.

MICRO & MINI MILLER

Plastic Pipes

DESCALING

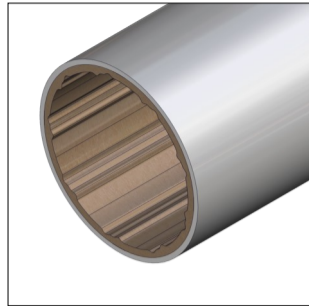

INTACT

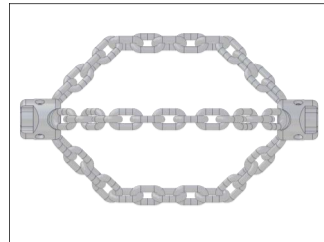

Original Chain (PVC)

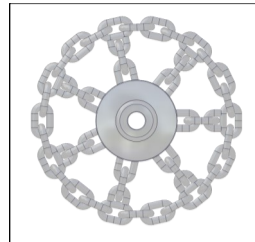

Cyclone Chain (PVC)



3D Chain (PVC)

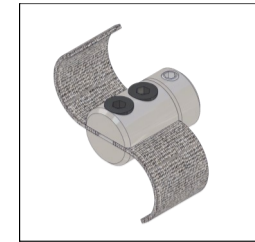

Smart Cutter™

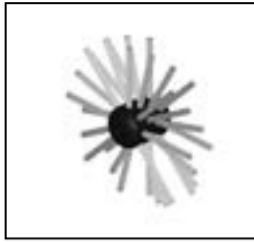

Nylon Cleaning Brush

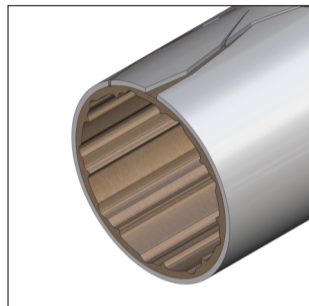

FRAGILE

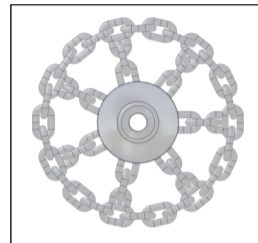

Cyclone Chain (PVC)

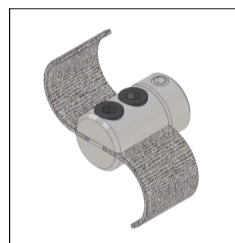

Smart Cutter™

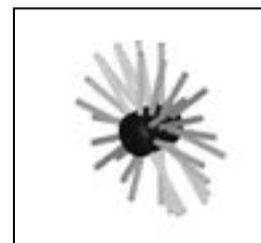

Nylon Cleaning Brush

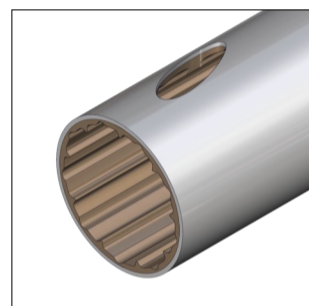

DAMAGED

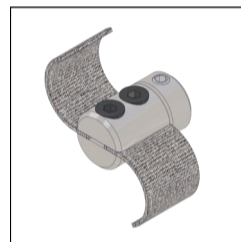

Smart Cutter™

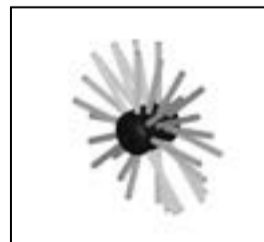

Nylon Cleaning Brush

SPECIAL

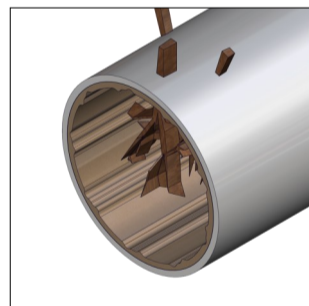

ROOTS

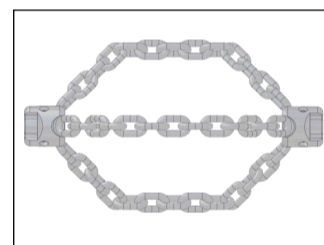

Original Chain (PVC)

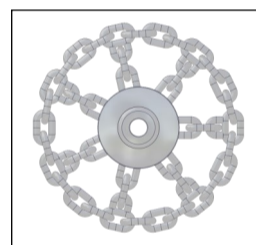

Cyclone Chain (PVC)



Twister Mini Express

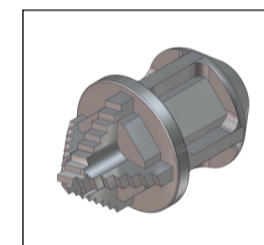

Special Drill Head (PVC)

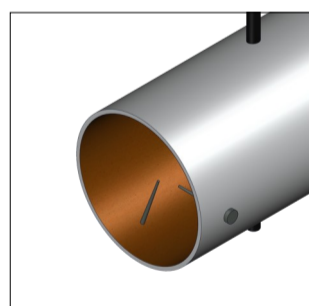

METAL

Refer to the Midi, Super Midi and Maxi Miller Range of Machines

Micro Miller

Shaft Diameter: **8 mm (1/3")**

Micro Miller Range: **12 metres (39 ft)**

Additional Extension:** **10 metres (32 ft)**

Recommended Diameter Range: **DN50 (2") to DN100 (4")**

Mini Miller

Shaft Diameter: **8 mm (1/3")**

Mini Miller Range: **16 metres (50 ft)**

Additional Extension:** **10 metres (32 ft)**

Recommended Diameter Range: **DN50 (2") to DN100 (4")**

** Shaft extension sold separately.

Available Tools

Original Chain (PVC)

3D Chain (PVC)

Cyclone Chain (PVC)

Smart Cutter™

Nylon Cleaning Brush*

Special Drill Head (PVC)

Twister Mini Express

Size Range

DN50 (2") - DN150 (6")

DN50 (2") - DN100 (4")

DN70 (3") - DN125 (5")

DN50 (2") - DN100 (4")

DN50 (2") - DN150 (6")

DN50 (2") - DN75 (3")

DN50 (2") & DN70 (3")

* Nylon cleaning brushes should only be used for removing fine dust or soft blockages.

STANDARD

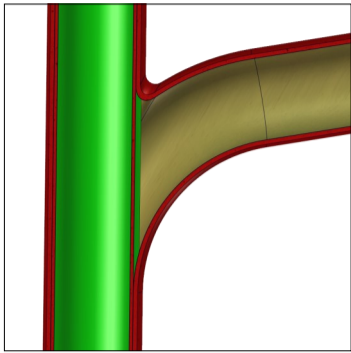

UNLINED



Twister Mini Express

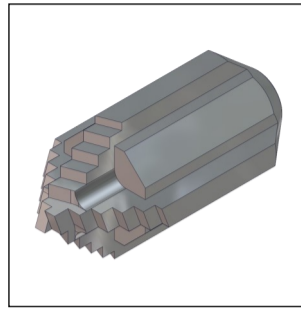

Special Drill Head

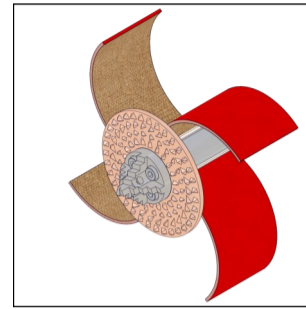

Smart Cutter™

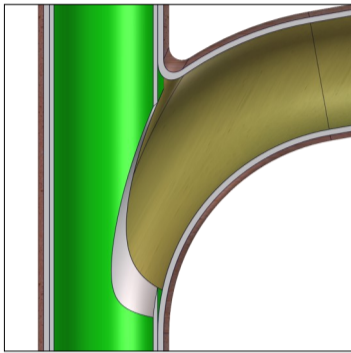

OPENED

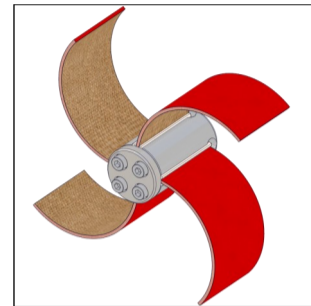

Smart Cutter™

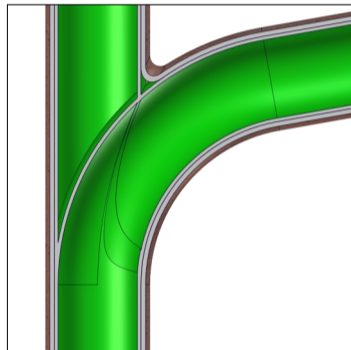

LINED



Twister Mini Express

SPECIAL

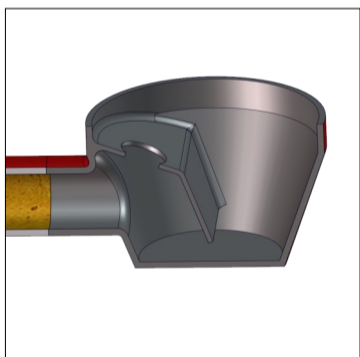

FLOOR DRAIN

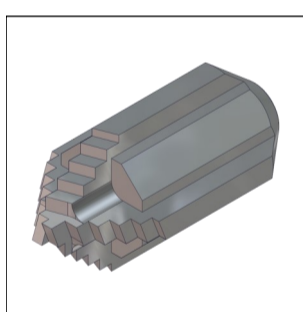

Special Drill Head

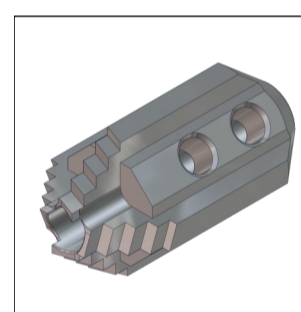

Special Drill Head (3D)

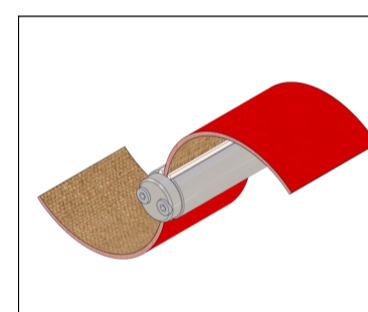

Smart Cutter™

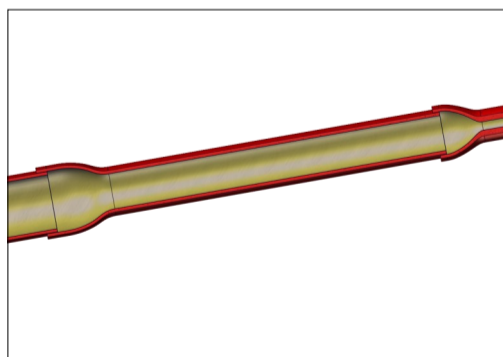

SIZE CHANGE

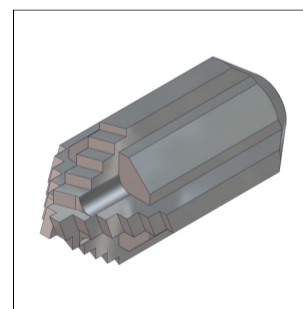

Special Drill Head

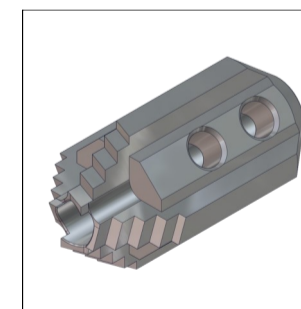

Special Drill Head (3D)

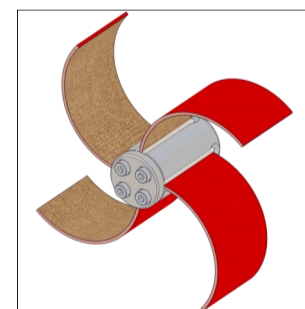

Smart Cutter™

Micro Miller

Shaft Diameter: 8 mm (1/3")

Range: 12 metres (39 ft)

Additional Extension: 10 metres (32 ft) (Sold Separately)

Recommended Diameter Range: DN50 (2") to DN75 (3")

Mini Miller

Shaft Diameter: 8 mm (1/3")

Range: 16 metres (50 ft)

Additional Extension: 10 metres (32 ft) (Sold Separately)

Recommended Diameter Range : DN50 (2") to DN75 (3")

Available Tools

Size Diameter

Smart Cutter™	DN50 (2") - DN75 (3")
Twister Mini Express	DN50 (2") - DN70 (3")
Special Drill Head	DN50 (2") - DN75 (3")
Special Drill Head (3D)	DN50 (2") - DN75 (3")

MICRO & MINI MILLER

Clay Pipes

S
T
A
N
D
A
R
D

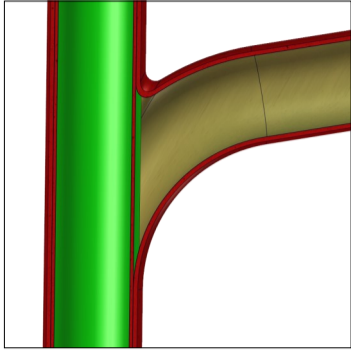

UNLINED



Twister Mini Express

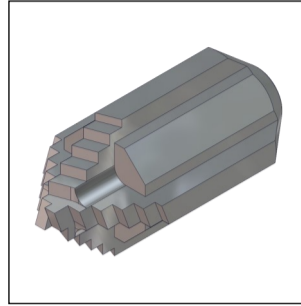

Special Drill Head

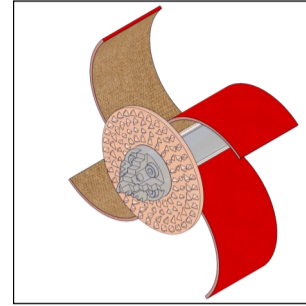

Smart Cutter™

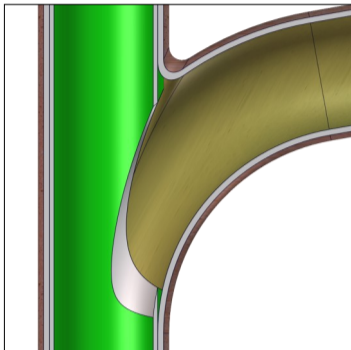

OPENED

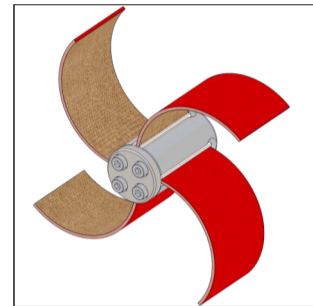

Smart Cutter™

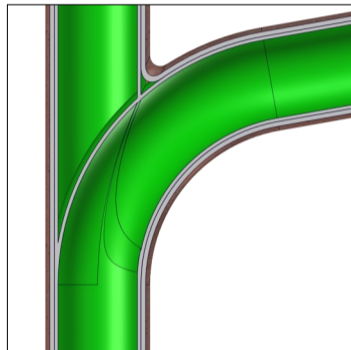

LINED



Twister Mini Express

S
P
E
C
I
A
L

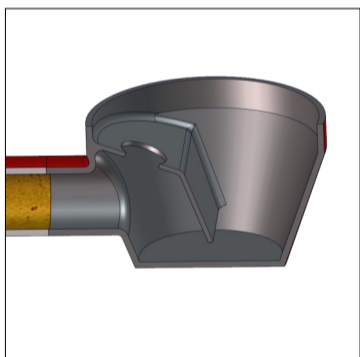

FLOOR DRAIN

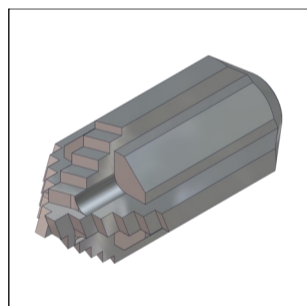

Special Drill Head

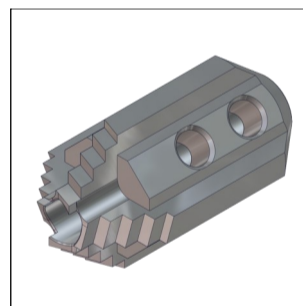

Special Drill Head (3D)



Smart Cutter™

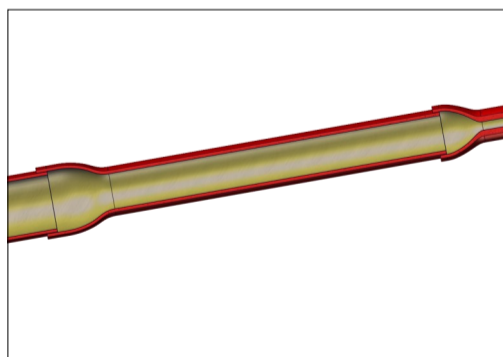

SIZE CHANGE

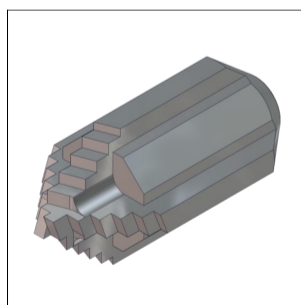

Special Drill Head

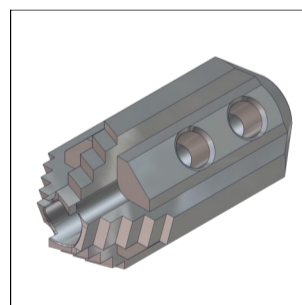

Special Drill Head (3D)

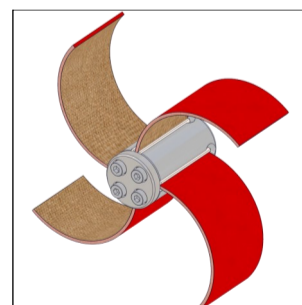

Smart Cutter™

Micro Miller

Shaft Diameter: 8 mm (1/3")

Range: 12 metres (39 ft)

Additional Extension: 10 metres (32 ft) (Sold Separately)

Recommended Diameter Range: DN50 (2") to DN75 (3")

Mini Miller

Shaft Diameter: 8 mm (1/3")

Range: 16 metres (50 ft)

Additional Extension: 10 metres (32 ft) (Sold Separately)

Recommended Diameter Range : DN50 (2") to DN75 (3")

Available Tools

Size Diameter

Smart Cutter™	DN50 (2") - DN75 (3")
Twister Mini Express	DN50 (2") - DN70 (3")
Special Drill Head	DN50 (2") - DN75 (3")
Special Drill Head (3D)	DN50 (2") - DN75 (3")

S
T
A
N
D
A
R
D

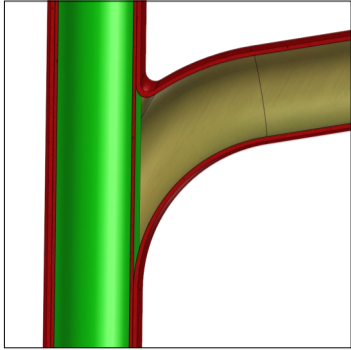

UNLINED



Twister Mini Express

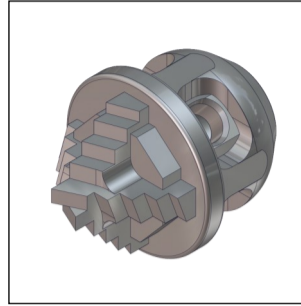

Special Drill Head (PVC)

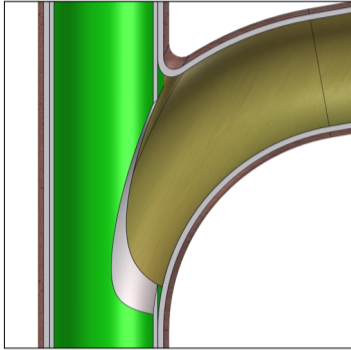

OPENED

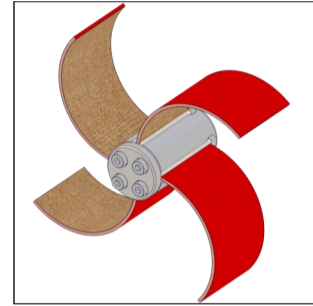

Smart Cutter™

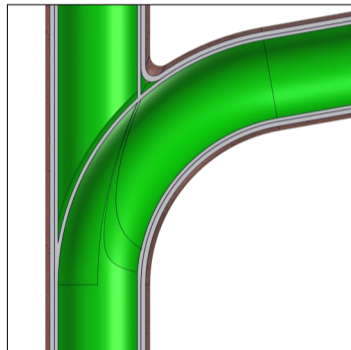

LINED



Twister Mini Express

S
P
E
C
I
A
L

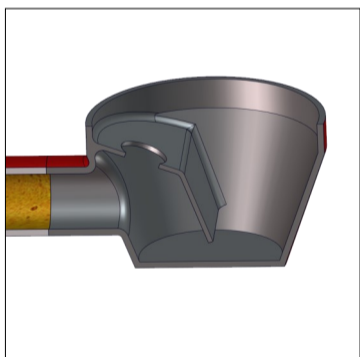

FLOOR DRAIN

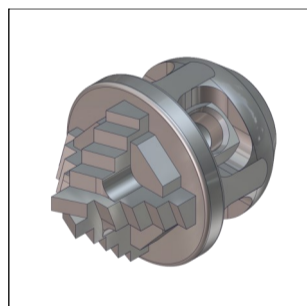

Special Drill Head (PVC)



Smart Cutter™

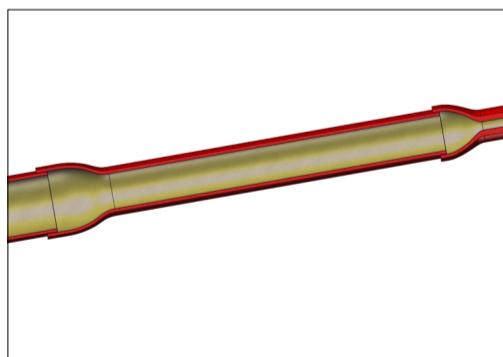

SIZE CHANGE

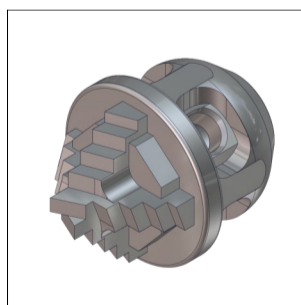

Special Drill Head (PVC)

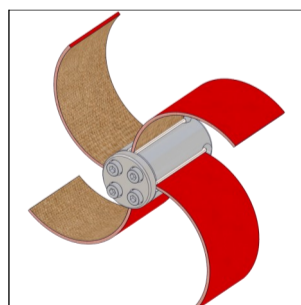

Smart Cutter™

Micro Miller

Shaft Diameter: 8 mm (1/3")

Range: 12 metres (39 ft)

Additional Extension: 10 metres (32 ft) (Sold Separately)

Recommended Diameter Range: DN50 (2") to DN75 (3")

Mini Miller

Shaft Diameter: 8 mm (1/3")

Range: 16 metres (50 ft)

Additional Extension: 10 metres (32 ft) (Sold Separately)

Recommended Diameter Range : DN50 (2") to DN75 (3")

Available Tools

Size Diameter

Smart Cutter	DN50 (2") - DN75 (3")
Twister Mini Express	DN50 (2") - DN70 (3")
Special Drill Head (PVC)	DN50 (2") - DN75 (3")